

## EGC 140-12 12 volt 140 Ah

### Specifications

Nominal Voltage		12V
Rated capacity (20 hour rate)		140Ah
Dimensions	Length	345±2mm(13.46inch)
	Width	172±2mm(6.77inch)
	Height	280±2mm(11.02inch)
	Total Height	285±2mm(11.22inch)
Approx. Weight		40kg(88.2lbs)±3%



### Outer dimensions (mm)

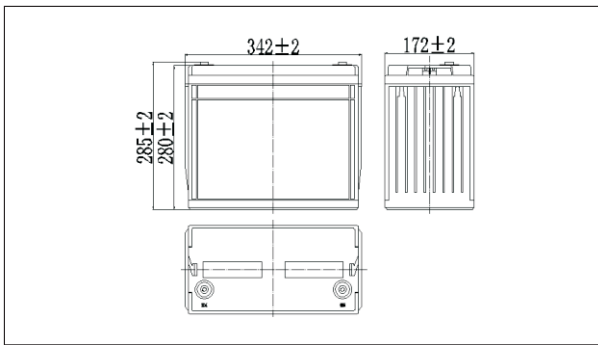

### Terminal Type (mm)

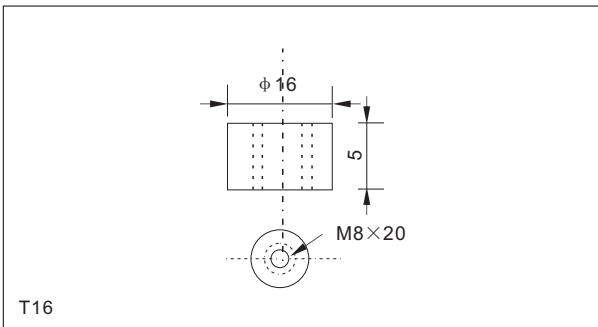

### Characteristics

Capacity (25°C)	100HR(10.8V)	185Ah
	20HR(10.8V)	140Ah
	10HR(10.8V)	134Ah
Terminal type		T16
Internal resistance (Fully charged, 25°C)		Approx. 4.2m Ω
Capacity affected by temperature (10HR)	40°C	102%
	25°C	100%
	0°C	85%
	-15°C	65%
Self-discharge (25°C)	3 months	Remaining Capacity:91%
	6 months	Remaining Capacity:82%
	12 months	Remaining Capacity:65%
Nominal operating temperature		25°C ±3°C(77°F ±5°F)
Operating temperature range	Discharge	-15°C~50°C(5°F~122°F)
	Charge	-10°C~50°C(14°F~122°F)
	Storage	-20°C~50°C(-4°F~122°F)
Float charging voltage(25°C)		13.50 to 13.80V Temperature compensation: -18mV/°C
Cyclic charging voltage(25°C)		14.50 to 15.00V Temperature compensation: -30mV/°C
Maximum charging current		40.2A
Maximum discharge current		1000A(5 sec.)
Designed floating life(20°C)		10years

### Construction

Component	Positive plate	Negative plate	Container	Cover	Separator	Electrolyte	Safety valve	Terminal
Raw material	Lead dioxide	Lead	ABS	ABS	AGM	Sulfuric acid	Rubber	Copper

### Constant Current Discharge Characteristics Unit:A(25°C,77°F)

F.V/Time	10min	15min	30min	60min	2h	3h	4h	5h	8h	10h	20h
9.60V	292	225	135	82.8	49.0	35.3	28.2	24.1	16.5	13.6	7.23
9.90V	283	220	132	81.6	48.7	35.1	28.0	23.9	16.4	13.6	7.22
10.2V	272	212	128	79.5	48.2	34.8	27.8	23.7	16.3	13.6	7.19
10.5V	260	204	125	77.0	47.5	34.6	27.6	23.6	16.2	13.5	7.15
10.8V	245	194	120	74.5	46.3	33.5	26.8	22.9	15.7	13.4	7.10

### Constant Power Discharge Characteristics Unit:A(25°C,77°F)

F.V/Time	10min	15min	30min	60min	2h	3h	4h	5h	8h	10h	20h
9.60V	3155	2472	1511	944	567	518	331	284	196	163	86.8
9.90V	3060	2412	1481	930	564	412	329	283	195	163	86.6
10.2V	2934	2324	1435	906	559	409	327	281	194	162	86.3
10.5V	2808	2244	1401	878	550	407	325	279	193	161	85.8
10.8V	2650	2126	1349	850	536	394	315	270	187	160	85.2

Note: The above characteristics data can be obtained within three charge or discharge cycles.

## EGC 140-12 12 volt 140 Ah

### Discharge characteristics (25°C)

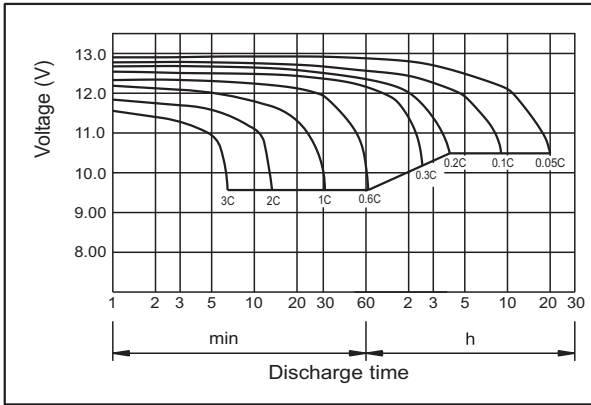

### Charging characteristics (25°C)

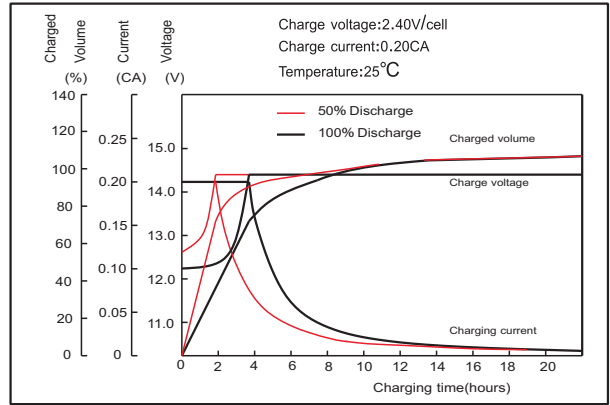

### Temperature effects on Capacity

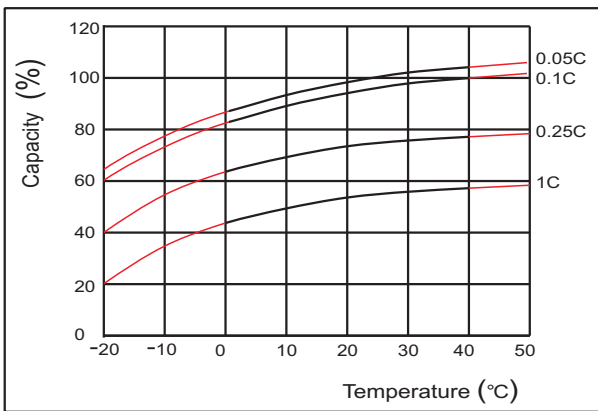

### Self-discharge characteristics

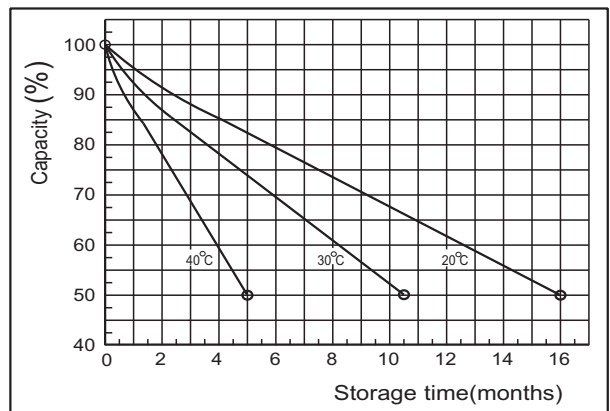

### Floating life on Temperature

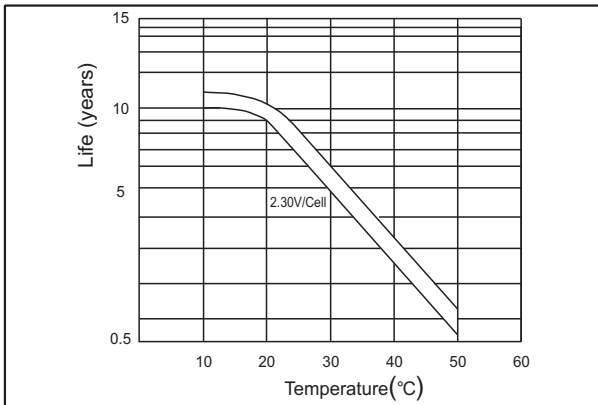

### Cycle life on D.O.D (25°C)

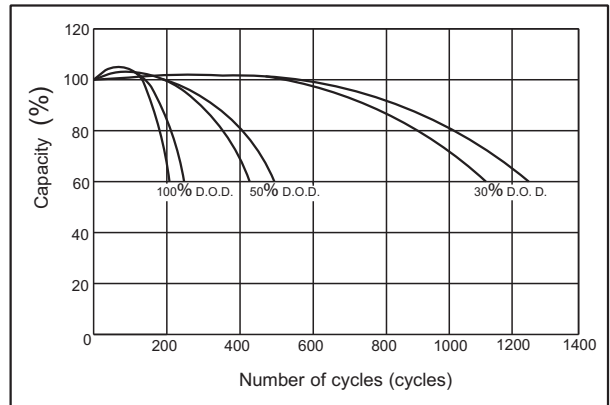

### The relationship for OCV and Capacity (25°C)

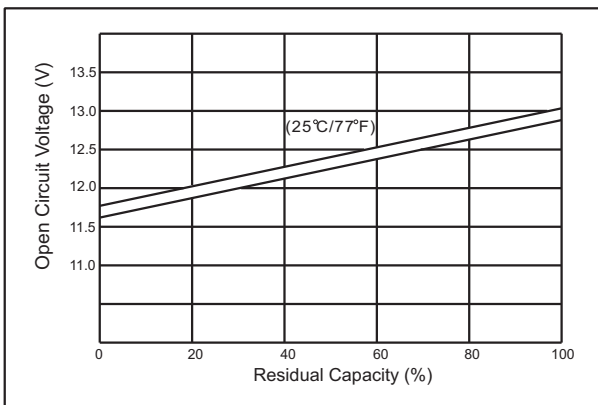

### The relationship for Charging voltage and Temperature

