

## EGC 150-12 12 volt 157 Ah

### Specifications

Nominal Voltage	12V	
Rated capacity (20 hour rate)	157Ah	
Dimensions	Length	485±2mm(19.09inch)
	Width	172±2mm(6.77inch)
	Height	240±2mm(9.45inch)
	Total Height	240±2mm(9.45inch)
Approx. Weight	44.0kg(97.1lbs)±3%	

### Outer dimensions (mm)

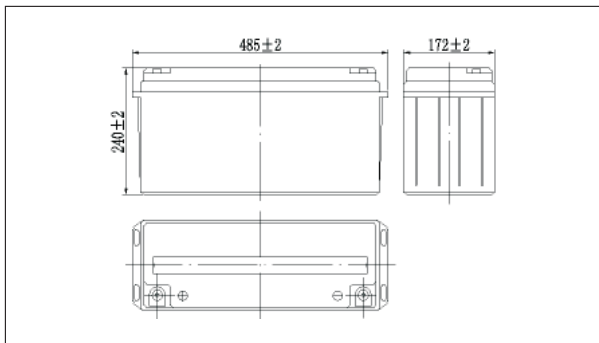

### Terminal Type (mm)

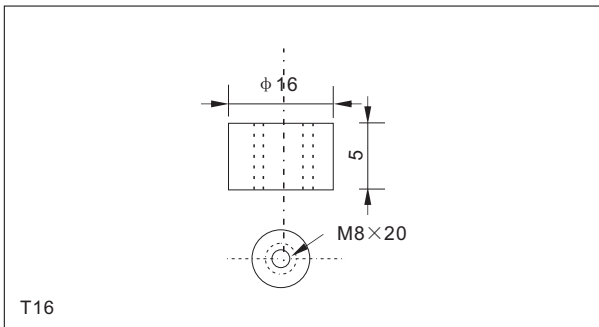

### Construction

Component	Positive plate	Negative plate	Container	Cover	Separator	Electrolyte	Safety valve	Terminal
Raw material	Lead dioxide	Lead	ABS	ABS	AGM	Sulfuric acid	Rubber	Copper

### Constant Current Discharge Characteristics Unit:A(25°C,77°F)

F.V/Time	10min	15min	30min	60min	2h	3h	4h	5h	8h	10h	20h
9.60V	336	259	155	95.2	56.3	40.5	32.4	27.6	19.0	15.7	8.31
9.90V	326	253	152	93.7	55.9	40.3	32.2	27.5	18.9	15.6	8.29
10.2V	312	243	147	91.4	55.4	40.0	31.9	27.3	18.8	15.6	8.27
10.5V	299	235	143	88.5	54.6	39.7	31.7	27.1	18.6	15.5	8.22
10.8V	282	222	138	85.7	53.2	38.5	30.8	26.3	18.1	15.4	8.16

### Constant Power Discharge Characteristics Unit:A(25°C,77°F)

F.V/Time	10min	15min	30min	60min	2h	3h	4h	5h	8h	10h	20h
9.60V	3626	2841	1737	1085	652	477	381	327	226	187	99.7
9.90V	3517	2773	1702	1069	648	474	378	325	224	187	99.5
10.2V	3372	2670	1650	1042	642	471	376	323	223	186	99.2
10.5V	3227	2579	1610	1009	632	467	373	320	221	185	98.6
10.8V	3046	2443	1551	976	616	453	362	311	215	184	97.9

Note: The above characteristics data can be obtained within three charge or discharge cycles.



### Characteristics

Capacity (25°C)	100HR(10.8V)	210Ah
	20HR(10.8V)	157Ah
	10HR(10.8V)	150Ah
Terminal type		T16
Internal resistance (Fully charged,25°C)		Approx.3.5m Ω
Capacity affected by temperature (10HR)	40°C	102%
	25°C	100%
	0°C	85%
	-15°C	65%
Self-discharge (25°C)	3 months	Remaining Capacity:91%
	6 months	Remaining Capacity:82%
	12 months	Remaining Capacity:65%
Nominal operating temperature		25°C ±3°C(77°F ±5°F)
Operating temperature range	Discharge	-15°C~50°C(5°F~122°F)
	Charge	-10°C~50°C(14°F~122°F)
	Storage	-20°C~50°C(-4°F~122°F)
Float charging voltage(25°C)		13.50 to 13.80V Temperature compensation: -18mV/°C
Cyclic charging voltage(25°C)		14.50 to 15.00V Temperature compensation: -30mV/°C
Maximum charging current		45A
Maximum discharge current		1200A(5 sec.)
Designed floating life(20°C)		10years

## EGC150-12 12 volt 157 Ah

### Discharge characteristics(25°C)

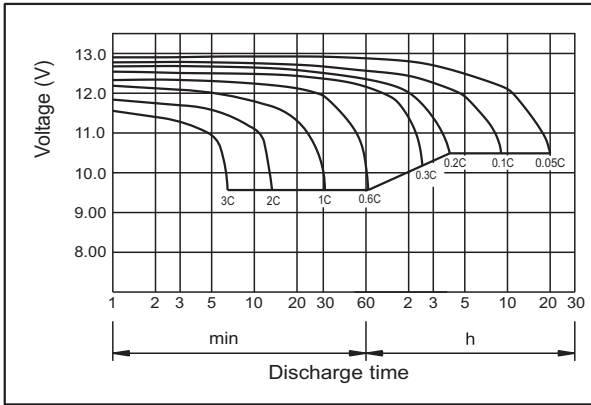

### Charging characteristics (25°C)

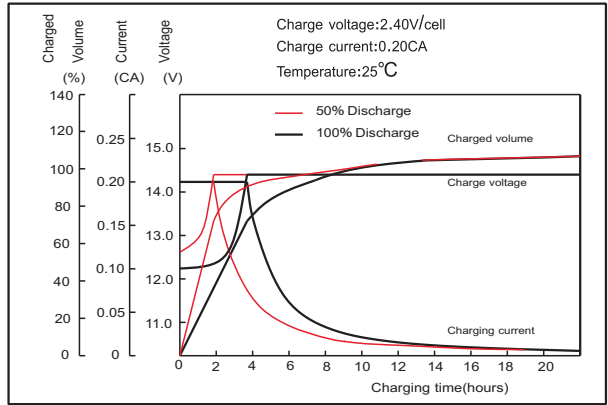

### Temperature effects on Capacity

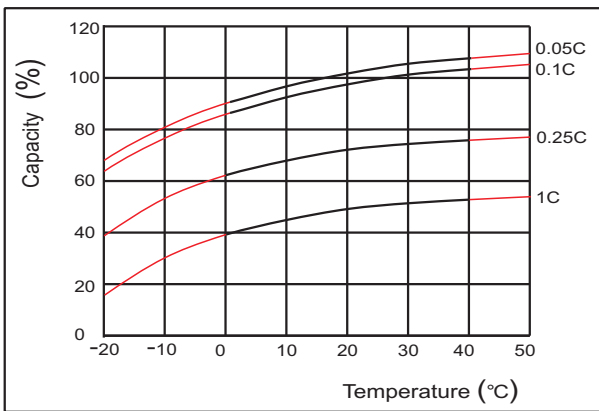

### Self-discharge characteristics

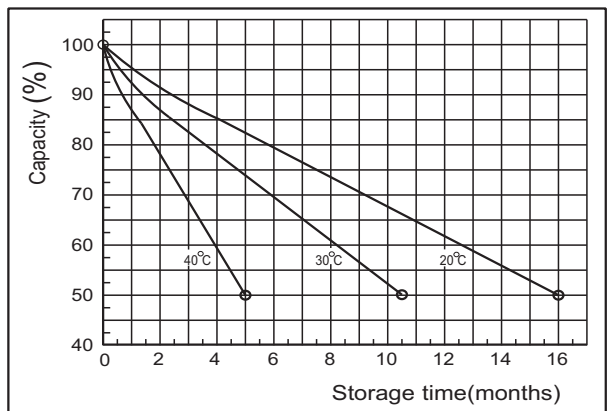

### Floating life on Temperature

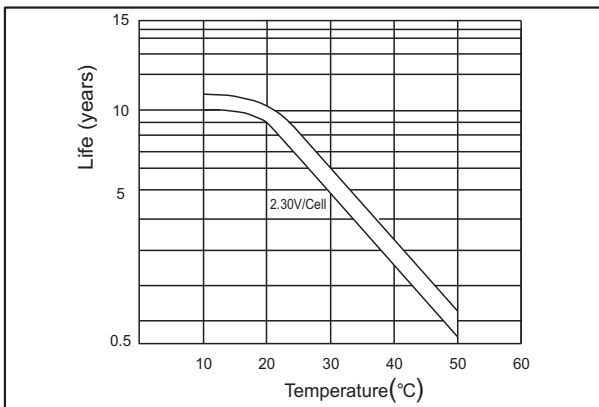

### Cycle life on D.O.D (25°C)

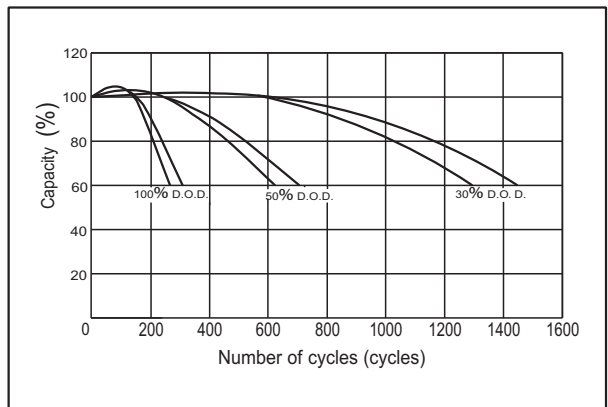

### The relationship for OCV and Capacity (25°C)

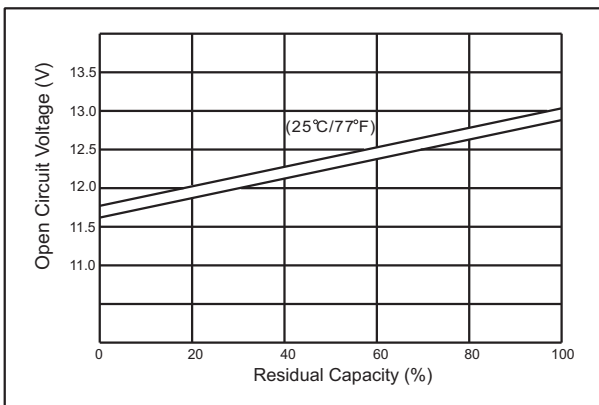

### The relationship for Charging voltage and Temperature

