

## EGC 200-12 12 volt 210 Ah

### Specifications

Nominal Voltage	12V	
Rated capacity (20 hour rate)	210Ah	
Dimensions	Length	522±2mm(20.55inch)
	Width	238±2mm(9.37inch)
	Height	218±2mm(8.58inch)
	Total Height	222±2mm(8.74inch)
Approx. Weight	62.5kg(137.8lbs)±3%	

### Outer dimensions (mm)

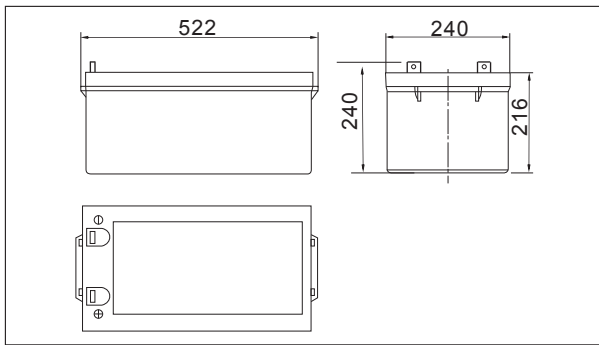

### Terminal Type (mm)

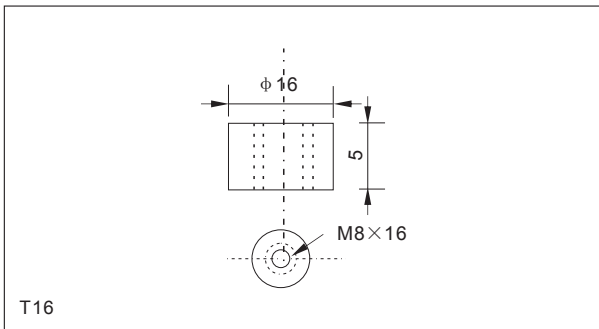

### Characteristics

Capacity (25°C)	100HR(10.8V)	290Ah
	20HR(10.8V)	210Ah
	10HR(10.8V)	200Ah
Terminal type		T16
Internal resistance (Fully charged, 25°C)		Approx. 3m Ω
Capacity affected by temperature (10HR)	40°C	102%
	25°C	100%
	0°C	85%
	-15°C	65%
Self-discharge (25°C)	3 months	Remaining Capacity:91%
	6 months	Remaining Capacity:82%
	12 months	Remaining Capacity:65%
Nominal operating temperature		25°C ±3°C(77°F ±5°F)
Operating temperature range	Discharge	-15°C~50°C(5°F~122°F)
	Charge	-10°C~50°C(14°F~122°F)
	Storage	-20°C~50°C(-4°F~122°F)
Float charging voltage(25°C)		13.50 to 13.80V Temperature compensation: -18mV/°C
Cyclic charging voltage(25°C)		14.50 to 15.00V Temperature compensation: -30mV/°C
Maximum charging current		60A
Maximum discharge current		1400A(5 sec.)
Designed floating life(20°C)		10years

### Construction

Component	Positive plate	Negative plate	Container	Cover	Separator	Electrolyte	Safety valve	Terminal
Raw material	Lead dioxide	Lead	ABS	ABS	AGM	Sulfuric acid	Rubber	Copper

### Constant Current Discharge Characteristics Unit:A(25°C,77°F)

F.V/Time	15min	30min	60min	2h	3h	4h	5h	6h	8h	10h	20h
9.60V	343	205	126	74.5	53.7	42.9	36.6	31.8	25.2	20.8	11.0
9.90V	334	201	124	74.1	53.4	42.6	36.4	31.6	25.0	20.7	11.0
10.2V	322	195	121	73.4	53.0	42.3	36.2	31.4	24.9	20.7	11.0
10.5V	311	190	117	72.3	52.6	42.0	35.9	31.2	24.7	20.5	10.9
10.8V	295	183	113	70.5	51.1	40.8	34.8	30.3	23.9	20.4	10.8

### Constant Power Discharge Characteristics Unit:W(25°C,77°F)

F.V/Time	15min	30min	60min	2h	3h	4h	5h	6h	8h	10h	20h
9.60V	3763	2300	1437	863	631	504	433	376	299	248	132
9.90V	3673	2254	1416	858	628	501	430	374	297	247	132
10.2V	3537	2185	1380	850	623	498	427	372	295	247	131
10.5V	3417	2132	1337	838	619	494	424	369	293	245	131
10.8V	3236	2054	1293	816	600	479	412	358	284	244	130

Note: The above characteristics data can be obtained within three charge or discharge cycles.

## EGC 200-12 12 volt 210 Ah

### Discharge characteristics(25°C)

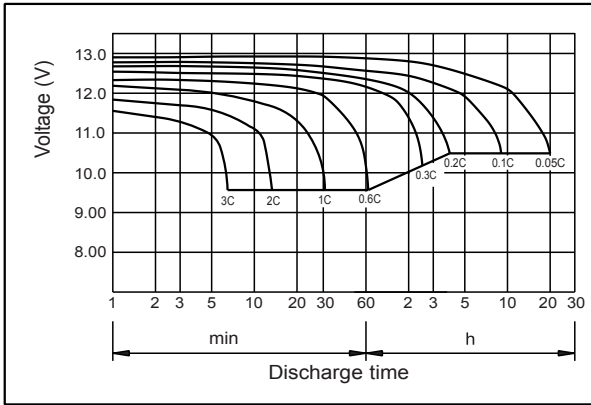

### Charging characteristics (25°C)

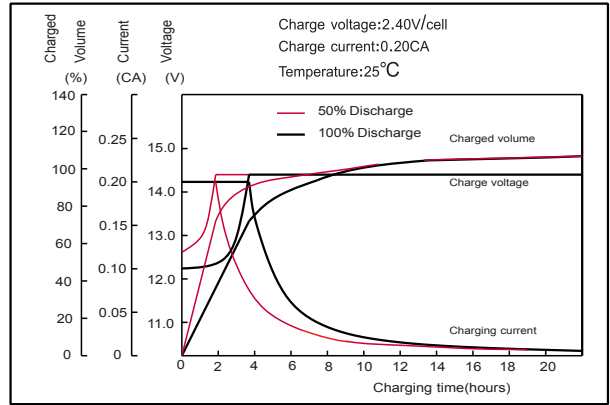

### Temperature effects on Capacity

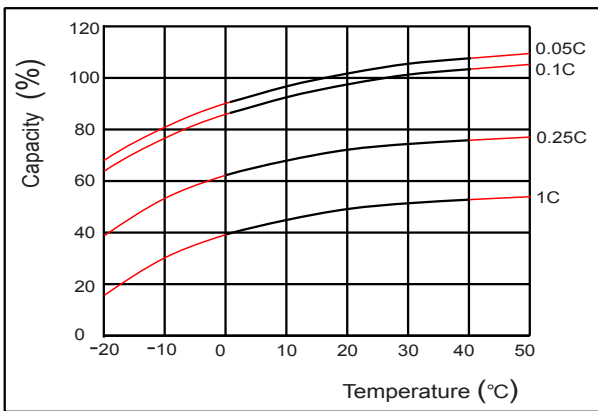

### Self-discharge characteristics

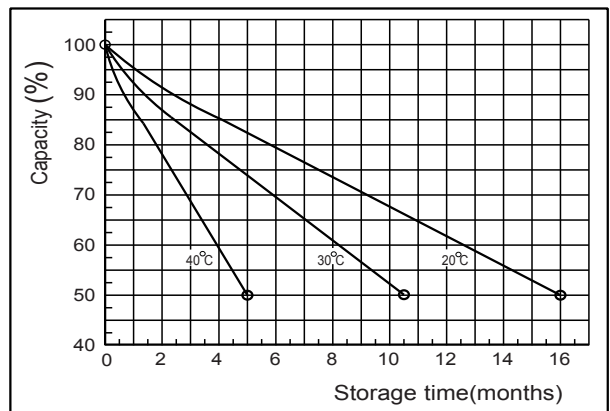

### Floating life on Temperature

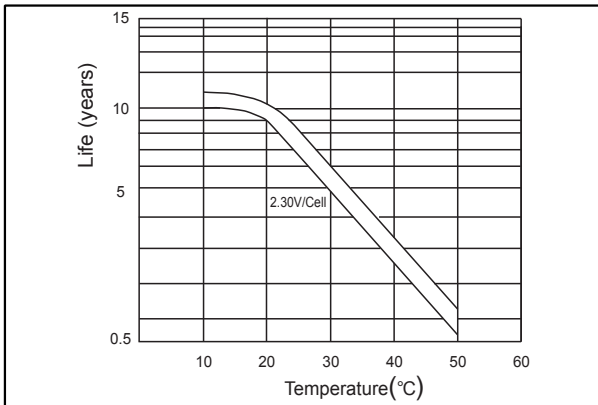

### Cycle life on D.O.D (25°C)

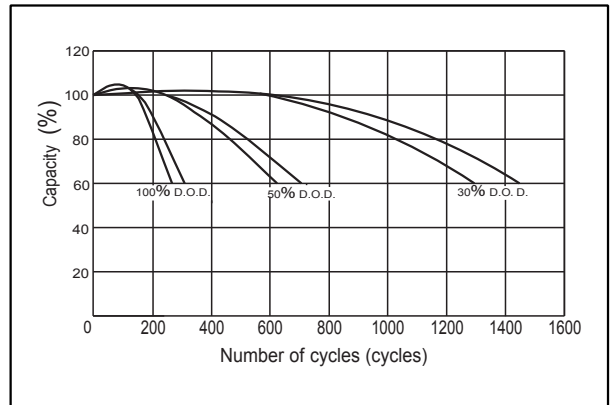

### The relationship for OCV and Capacity (25°C)

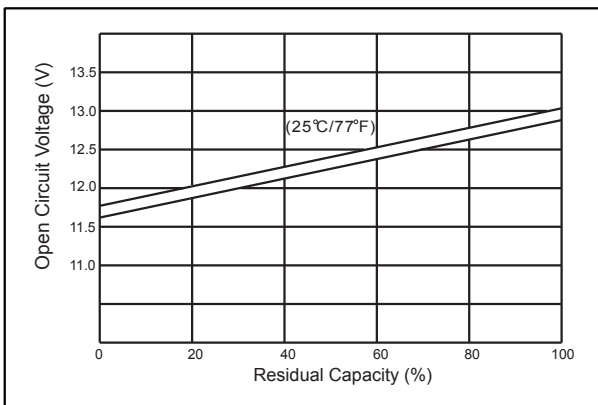

### The relationship for Charging voltage and Temperature

