

## EGC 250-12 12 volt 260 Ah

### Specifications

Nominal Voltage	12V	
Rated capacity (20 hour rate)	260Ah	
Dimensions	Length	521±2mm(20.51inch)
	Width	269±2mm(10.59inch)
	Height	220±2mm(8.66inch)
	Total Height	224±2mm(8.82inch)
Approx. Weight	74.5kg(164.2lbs)±3%	



### Outer dimensions (mm)

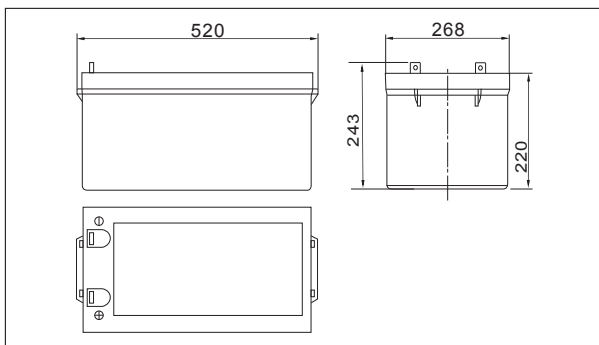

### Terminal Type (mm)

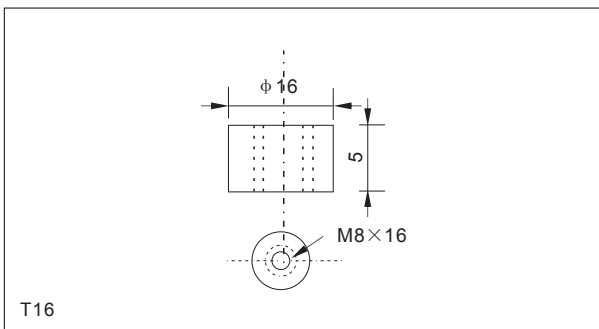

### Characteristics

Capacity (25°C)	100HR(10.8V)	365Ah
	20HR(10.8V)	260Ah
	10HR(10.8V)	250Ah
Terminal type		T16
Internal resistance (Fully charged, 25°C)		Approx. 2.6m Ω
Capacity affected by temperature (10HR)	40°C	102%
	25°C	100%
	0°C	85%
	-15°C	65%
Self-discharge (25°C)	3 months	Remaining Capacity:91%
	6 months	Remaining Capacity:82%
	12 months	Remaining Capacity:65%
Nominal operating temperature		25°C ±3°C(77°F ±5°F)
Operating temperature range	Discharge	-15°C~50°C(5°F~122°F)
	Charge	-10°C~50°C(14°F~122°F)
	Storage	-20°C~50°C(-4°F~122°F)
Float charging voltage(25°C)		13.50 to 13.80V Temperature compensation: -18mV/°C
Cyclic charging voltage(25°C)		14.50 to 15.00V Temperature compensation: -30mV/°C
Maximum charging current		75A
Maximum discharge current		1500A(5 sec.)
Designed floating life(20°C)		10years

### Construction

Component	Positive plate	Negative plate	Container	Cover	Separator	Electrolyte	Safety valve	Terminal
Raw material	Lead dioxide	Lead	ABS	ABS	AGM	Sulfuric acid	Rubber	Copper

### Constant Current Discharge Characteristics Unit:A(25°C,77°F)

F.V/Time	15min	30min	60min	2h	3h	4h	5h	6h	8h	10h	20h
9.60V	428	256	158	93.2	67.1	53.6	45.8	39.8	31.5	26.0	13.8
9.90V	418	251	155	92.6	66.7	53.3	45.5	39.6	31.3	25.9	13.7
10.2V	403	243	151	91.8	66.3	52.9	45.2	39.3	31.1	25.8	13.7
10.5V	389	238	147	90.4	65.8	52.5	44.9	39.0	30.9	25.7	13.6
10.8V	368	229	142	88.1	63.8	51.0	43.5	37.8	29.9	25.5	13.5

### Constant Power Discharge Characteristics Unit:W(25°C,77°F)

F.V/Time	15min	30min	60min	2h	3h	4h	5h	6h	8h	10h	20h
9.60V	4704	2875	1797	1079	789	630	541	470	374	310	165
9.90V	4591	2818	1770	1073	785	626	538	468	372	309	165
10.2V	4422	2732	1725	1063	779	622	534	464	369	308	164
10.5V	4271	2666	1671	1047	774	618	530	461	367	307	163
10.8V	4045	2568	1617	1021	750	599	515	447	356	304	162

Note: The above characteristics data can be obtained within three charge or discharge cycles.

## EGC 250-12 12 volt 260 Ah

### Discharge characteristics(25°C)

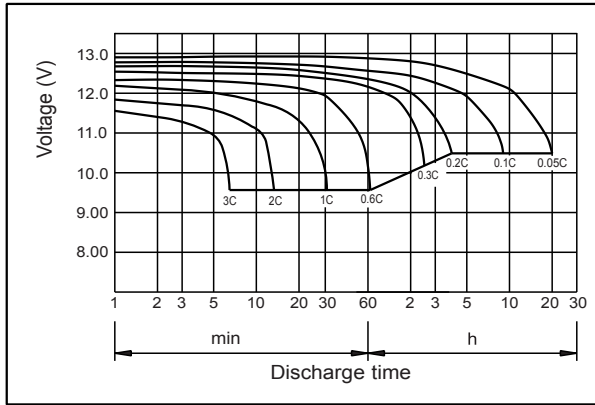

### Charging characteristics (25°C)

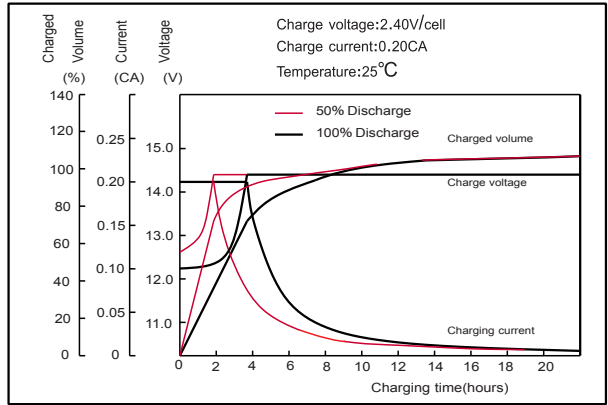

### Temperature effects on Capacity

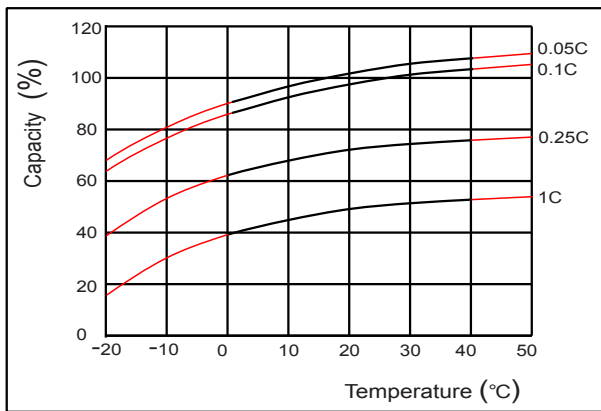

### Self-discharge characteristics

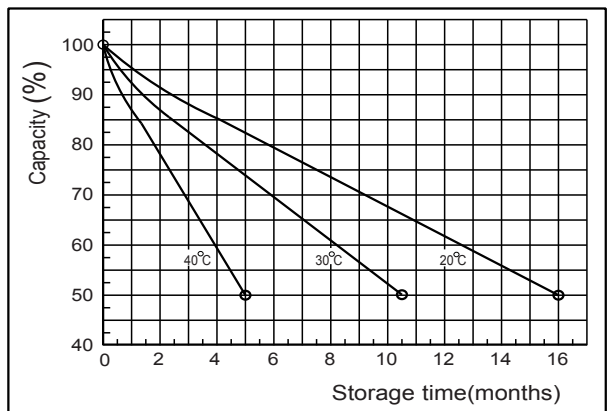

### Floating life on Temperature

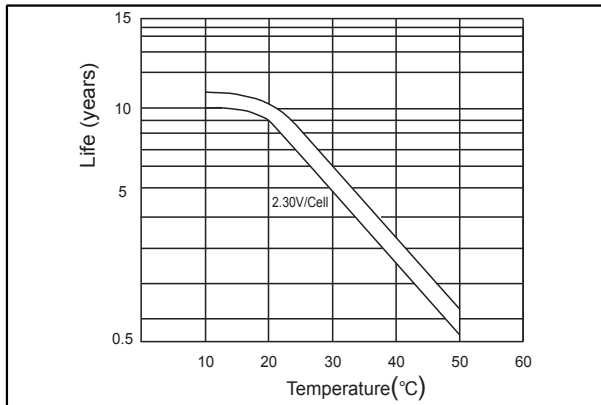

### Cycle life on D.O.D (25°C)

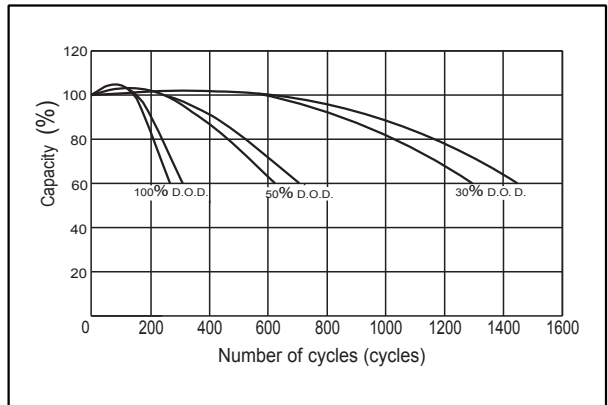

### The relationship for OCV and Capacity (25°C)

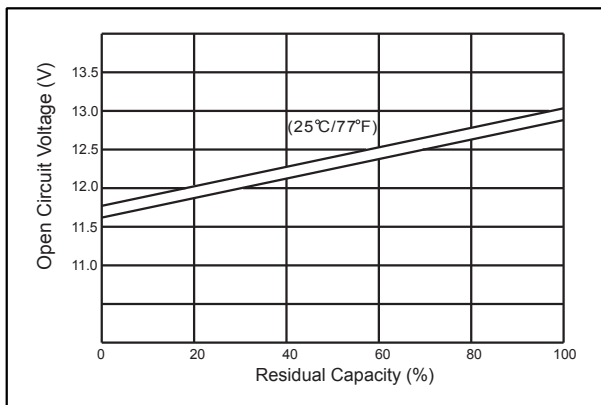

### The relationship for Charging voltage and Temperature

